

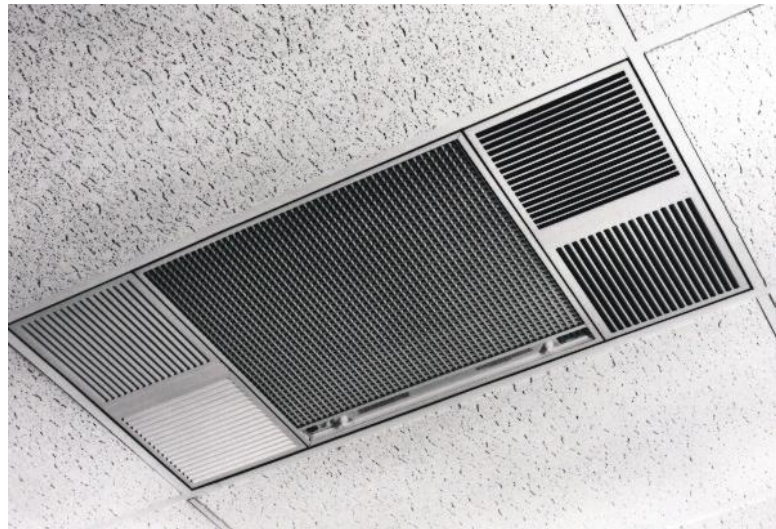

# AQE - X-11Q - CEILING MOUNTED AIR CLEANER SPECIFICATION SHEET

X-11Q Smokemaster® High Efficiency Electronic Air Cleaner

Commercial Indoor Air Quality Solutions



Features the Coanda 4-way airflow pattern.  
Adjustable louvers allow airflow refinement.

- Totally self-contained air cleaner
- Ultimate 'flush with ceiling' mounted workhorse
- Requires no filter replacement
- Features industrial-rated electronic filtration cell

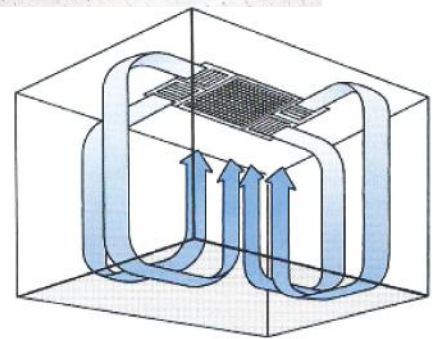

Superior performance and time tested design makes the Smokemaster® an excellent choice for removing tobacco smoke, pollen, mold spores and dust.



Air Quality Engineering, founded in 1973, is proud to offer a continued, superior level of experience in manufacturing complete air filtration systems that provide the highest performance, efficiency, and capacity for the money. Our sales and engineering team's mission is to identify the most cost-effective, high-quality solutions for our customers' needs, whether commercial, industrial or residential.



#2 Chootoo Road, South Aranguez, San Juan, Trinidad





# AQE - X-11Q - CEILING MOUNTED AIR CLEANER SPECIFICATION SHEET



## SMOKERS LIKE CLEAN AIR TOO!

The Model X-11Q Electronic Air cleaner:

- Comprehensive
- Inconspicuous
- Economical
- Quiet
- Assures your indoor air quality

## FEATURES & BENEFITS

- **High Efficiency** – Removes dust, smoke, pollen and other particles using high efficiency electronic collector cells.
- **Inconspicuous** – The attractive grille fits flush with the ceiling and is completely inconspicuous! The cabinet is hidden in the unused space above the ceiling.
- **Quiet** – Three-speed controller is standard and allows for quiet operation without sacrificing effectiveness. It's ideal for private offices, conference rooms or other areas where noise levels may be a factor.
- **Easy Installation** – Special-mounting brackets simplify the installation and do not require any additional space above cabinet height of 13 5/8".
- **Coanda Airflow** – Effective 360° Coanda airflow gently and evenly distributes clean air and returns dirty air to the unit. Coanda airflow destratifies air and eliminates "stuffy" air pockets.
- **Economical** – Permanent electronic collector cell assures low operating cost by eliminating costly filter replacements. Moreover, because collector cells offer no airflow restriction, only limited horsepower is necessary, thus reducing noise and electrical draw.
- **Comprehensive** – Two activated carbon filters for odor control included.

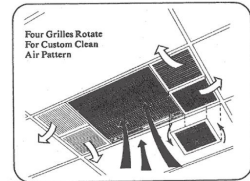
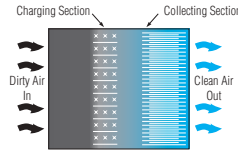

## HOW THE X-11Q WORKS

Contaminant particles, such as those in tobacco smoke, receive an electrical charge as they pass into the electronic cell and are then attracted to oppositely charged collector plates, where they are held, similar to the way that metal filings collect to a magnet. The air vent provides dilution control of gaseous contaminants. Standard activated carbon filter absorbs odors and gases to further freshen the air.

## SPECIFICATIONS / MODEL X-11Q

ELECTRICAL RATING:	120V 50/60 Hz or 220V 50/60 Hz
LOW SPEED:	500 CFM / 1.9 Amps
MEDIUM SPEED:	900 CFM / 2.2 Amps
HIGH SPEED:	1100 CFM / 2.6 Amps
COLOR:	White or Black
MOTOR:	1/10 Hp energy efficient motor, fan motor vibration isolation mounted
DIMENSIONS:	46 3/4" L x 22 3/4" W x 13 5/8" H (Fits 2' x 4' tile opening. *Power module adds 2" width above drop ceiling. Contact factory for non-drop ceiling installation information.)
WEIGHT:	83 lbs. installed 107 lbs. shipping
PRIMARY FILTER	
COLLECTION AREA:	105.8 Sq. Ft.
SORBENT MEDIA:	2 Activated Carbon Filters, 10" x 22" x .5"
AIR CLEANING EFFICIENCY:	Independent lab tested to the most current, stringent standards to deliver over 98.8% efficiency on 3 micron particles at medium speed.

## OPTIONAL ACCESSORIES

- Remote Fan Speed Control Kit
- Electronic Cell Wash Tank and Detergent

### Installation Schematic

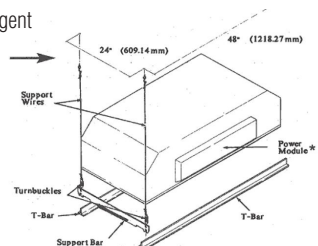

Specifications subject to change without notice.

This product is not available for resale or installation in California.



7140 Northland Drive North, Brooklyn Park, MN 55428-1520, USA  
**PHONE:** 763-531-9823 • **FAX:** 763-531-9900 • **TOLL FREE:** 1-800-328-0787  
**EMAIL:** info@air-quality-eng.com • [www.air-quality-eng.com](http://www.air-quality-eng.com)



#2 Chootoo Road, South Aranguéz, San Juan, Trinidad

